

- NOTES:
- ALL WORKS TO BE CONSTRUCTED IN ACCORDANCE WITH NRA SPECIFICATION FOR ROAD WORKS U.N.O.
 - ALL REINFORCED CONCRETE ON THIS DRAWING SHALL BE U.N.O.: 35N20 COVER = 50mm MIN
 - SURFACE FINISHES FOR CONCRETE:
 - CLASS F1 FOR ALL CONCRETE 100mm OR MORE BELOW GROUND LEVEL.
 - CLASS F3 FOR ALL EXPOSED CONCRETE ABOVE 100mm BELOW GROUND LEVEL.
 - ALL EXPOSED CORNERS ON CONCRETE SHALL BE CHAMFERED WITH 25mm x 25mm CHAMFERS.
 - ALL STRUCTURAL CONCRETE (HEADWALLS, RC MANHOLES, PETROL INTERCEPTOR SLABS) TO RECEIVE MC OUR 1680 (OR SIMILAR APPROVED TAR MODIFIED EPOXY RESIN) TO ALL BURIED SURFACES, TO FINISH 100mm BELOW GROUND LEVEL.
 - ALL SEWERS SHALL BE PRESSURE TESTED PRIOR TO BACKFILLING.
 - TYPE 1 GRANULAR MATERIAL: BROKEN STONE OR GRAVEL TO PASS 10mm SIEVE AND BE RETAINED ON 5mm SIEVE.
 - TYPE 2 GRANULAR MATERIAL: BROKEN STONE OR GRAVEL TO PASS 10mm = 25mm SIEVE, ACCORDING TO PIPE SIZE, (SEE TABLE) AND BE RETAINED ON 5mm SIEVE.
 - TYPE 3 SELECTED FILL: UNIFORM READILY COMPACTED MATERIAL FREE FROM TREE ROOTS, VEGETABLE MATTER, BUILDING DEBRIS, AND FROZEN SOIL AND EXCLUDING CLAY LUMPS RETAINED ON A 75mm SIEVE AND STONES RETAINED ON A 37.5mm SIEVE.
 - RIGID PIPES SHALL MEAN CAST OR SPUN IRON, CONCRETE, ASBESTOS CEMENT OR CLAY.
 - CLASS D400 MANHOLE COVER FRAMES TO BE 100mm DEEP IN ROADS, FOOTPATHS AND GREEN AREAS.
 - ALL AGGREGATES PROPOSED FOR USE ON THIS SCHEME SHALL MEET FULLY THE REQUIREMENTS OF THE TII SPECIFICATION FOR ROAD WORKS AND IN ADDITION THE REQUIREMENTS STATED IN STANDARD RECOMMENDATION S.R. 21:2014 GUIDANCE ON THE USE OF U.S. EN 12422:2002 +A1:2007-AGGREGATES FOR UNBOUND AND HYDRAULICALLY BOUND MATERIALS FOR USE IN CIVIL ENGINEERING WORK AND ROAD CONSTRUCTION.
 - FOUL SEWER MATERIAL TO BE AS PER IRISH WATER SPECIFICATION.
 - SURFACE WATER SEWER TO BE CONCRETE (CLASS H).
 - ENGINEERING BRICK: MIN. 1 ROW, MAX 3 ROWS TO BE INSTALLED UNDER MAINTENANCE COVER. ENGINEERING BRICK TO BE CLASS B TO IS EN 771.

TYPE 2 GRANULAR MATERIAL:

PIPE SIZE	100% PASSING
UP TO 225mm	10mm SIEVE
225 TO 450mm	20mm SIEVE
ABOVE 450mm	25mm SIEVE

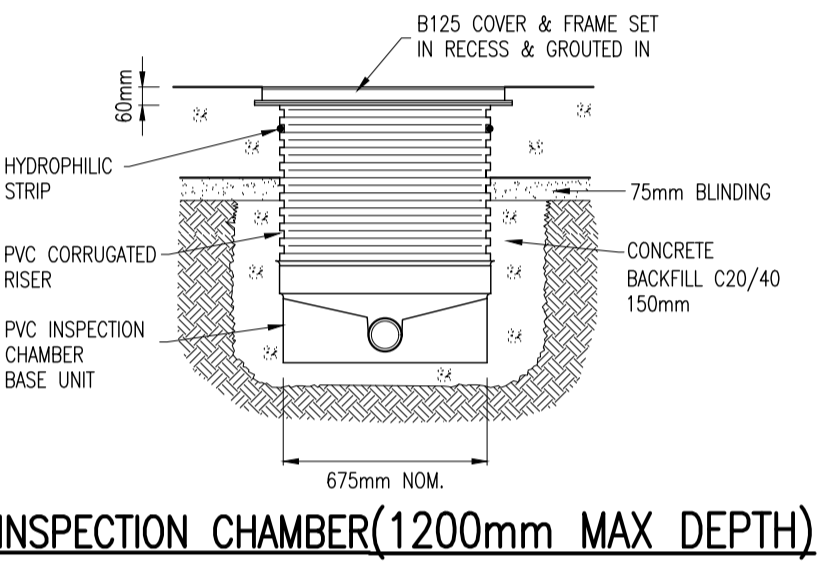
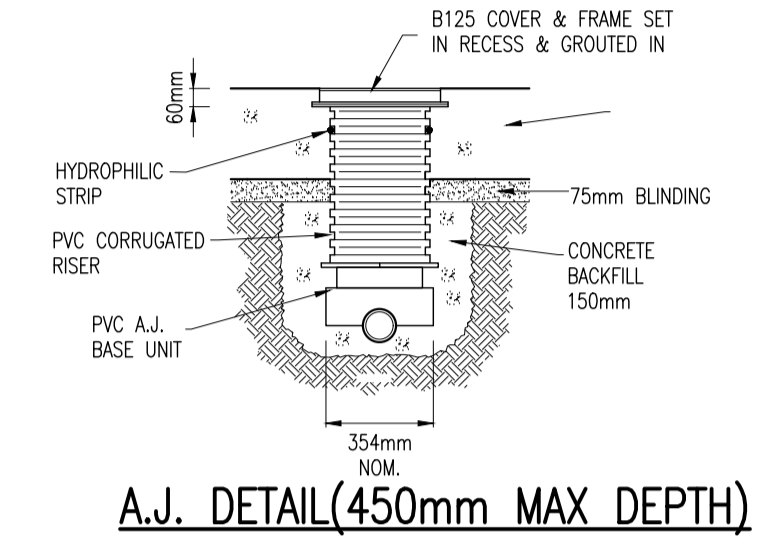
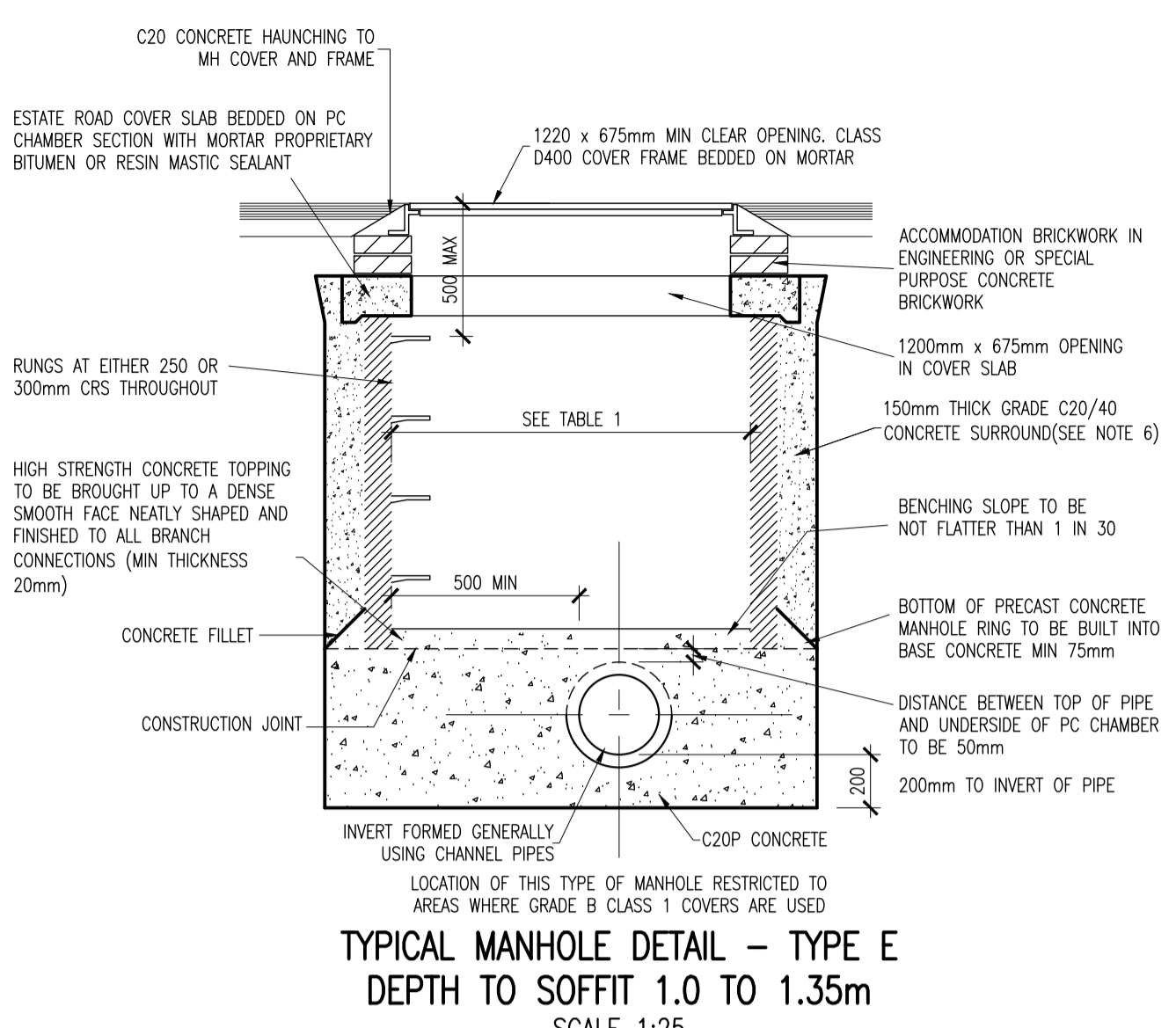
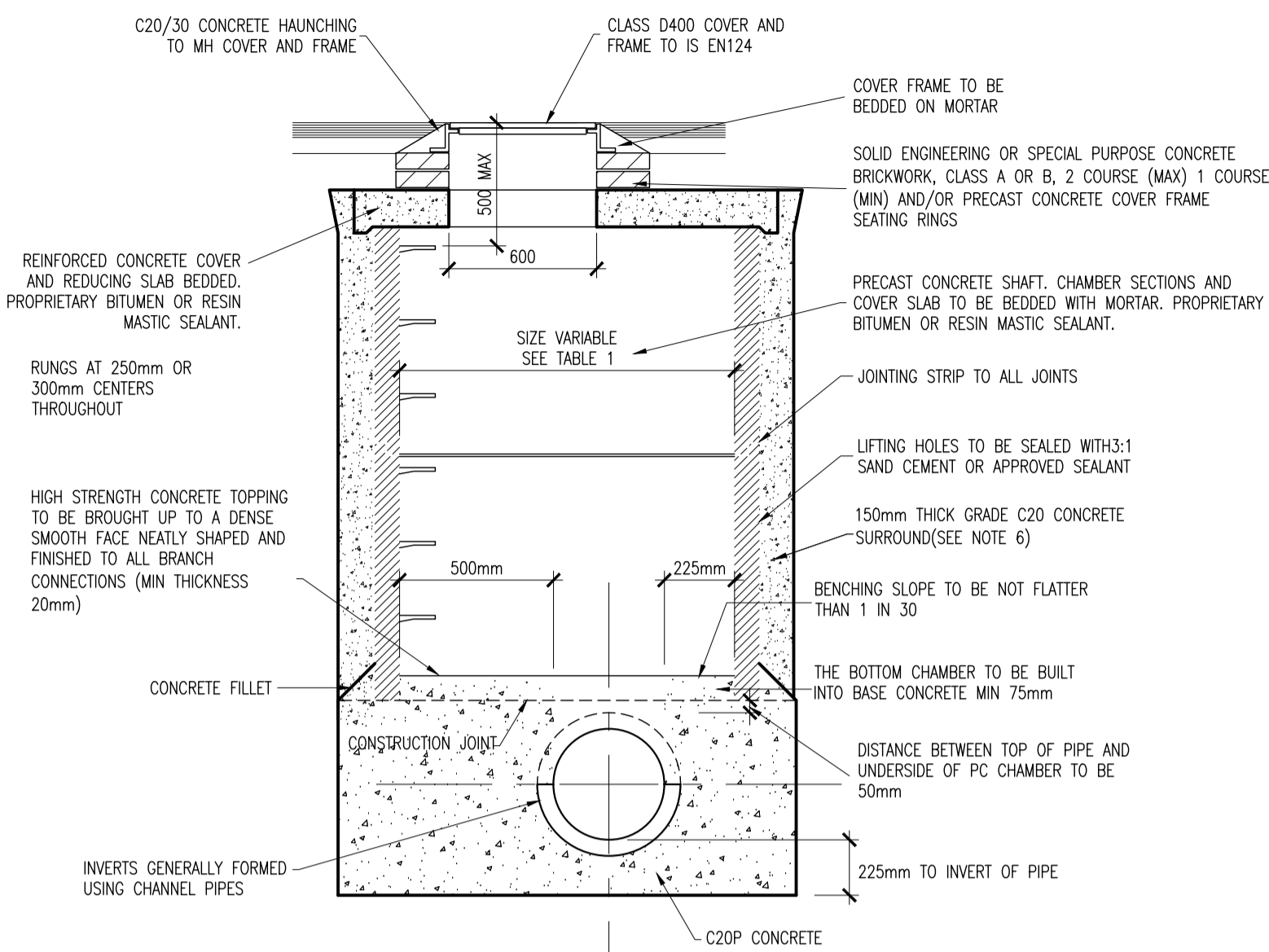

PIPE DIA	ROCKER PIPE LENGTH
150-450	0.5-0.75
451-750	0.75-1.0
750	SEEK GUIDANCE

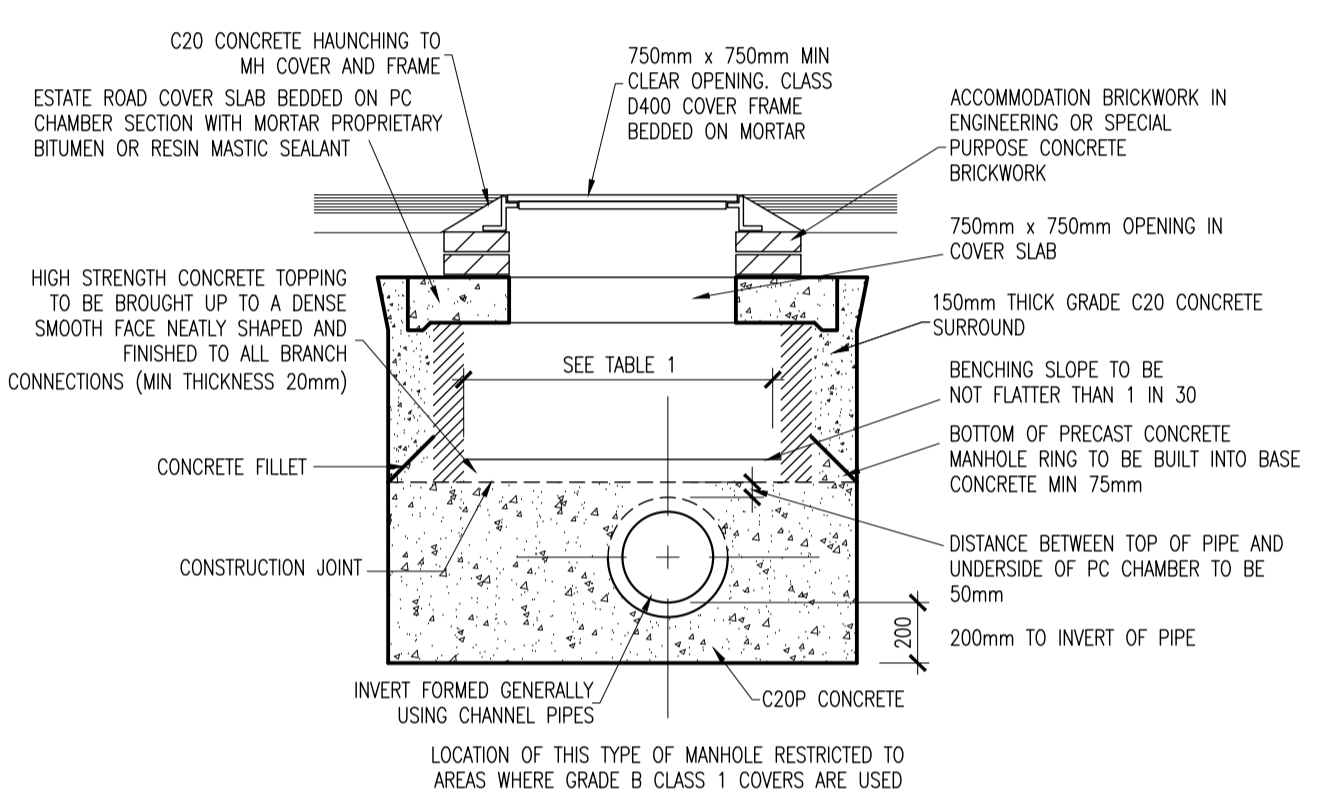
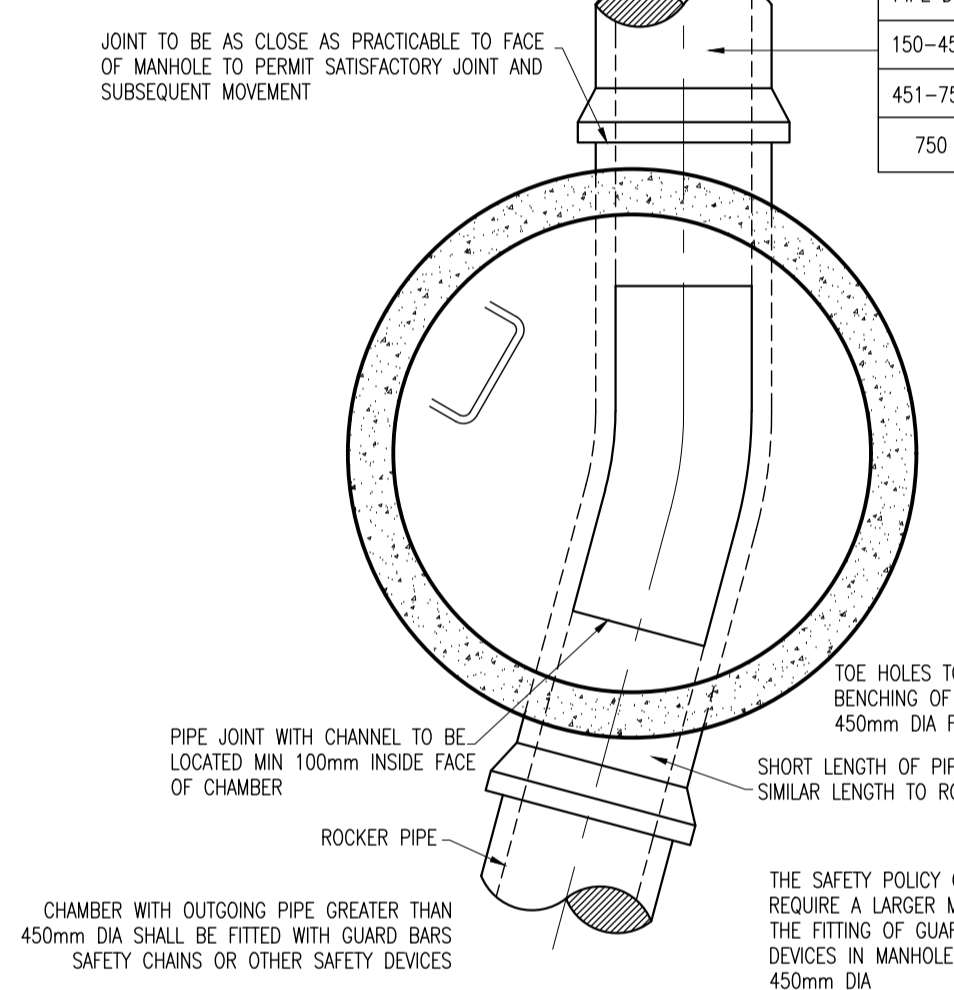

TYPICAL MANHOLE DETAIL - TYPE F
DEPTH TO SOFFIT LESS THAN 1.0m
SCALE 1:25

TYPICAL MANHOLE DETAIL - TYPE J
DEPTH TO SOFFIT 1.35 TO 3m
SCALE 1:25

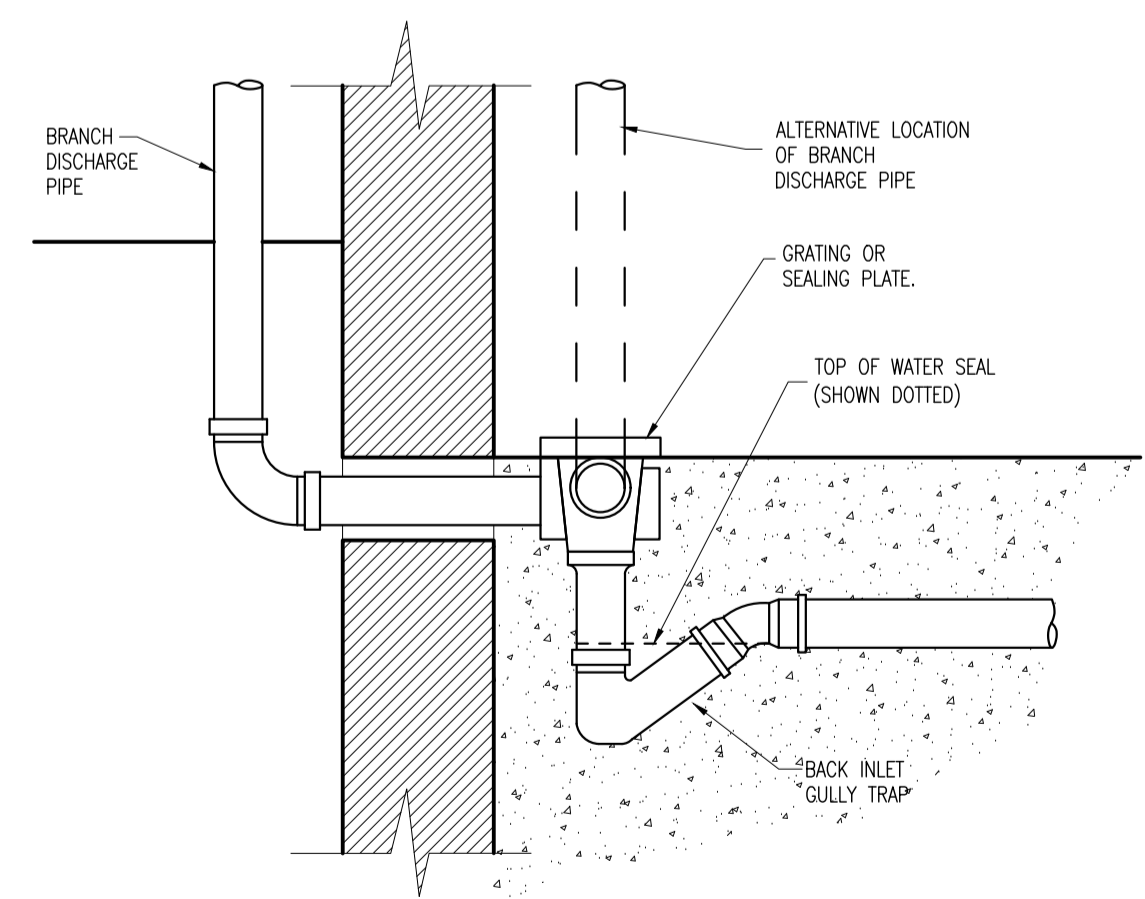

BACK INLET GULLY TRAP

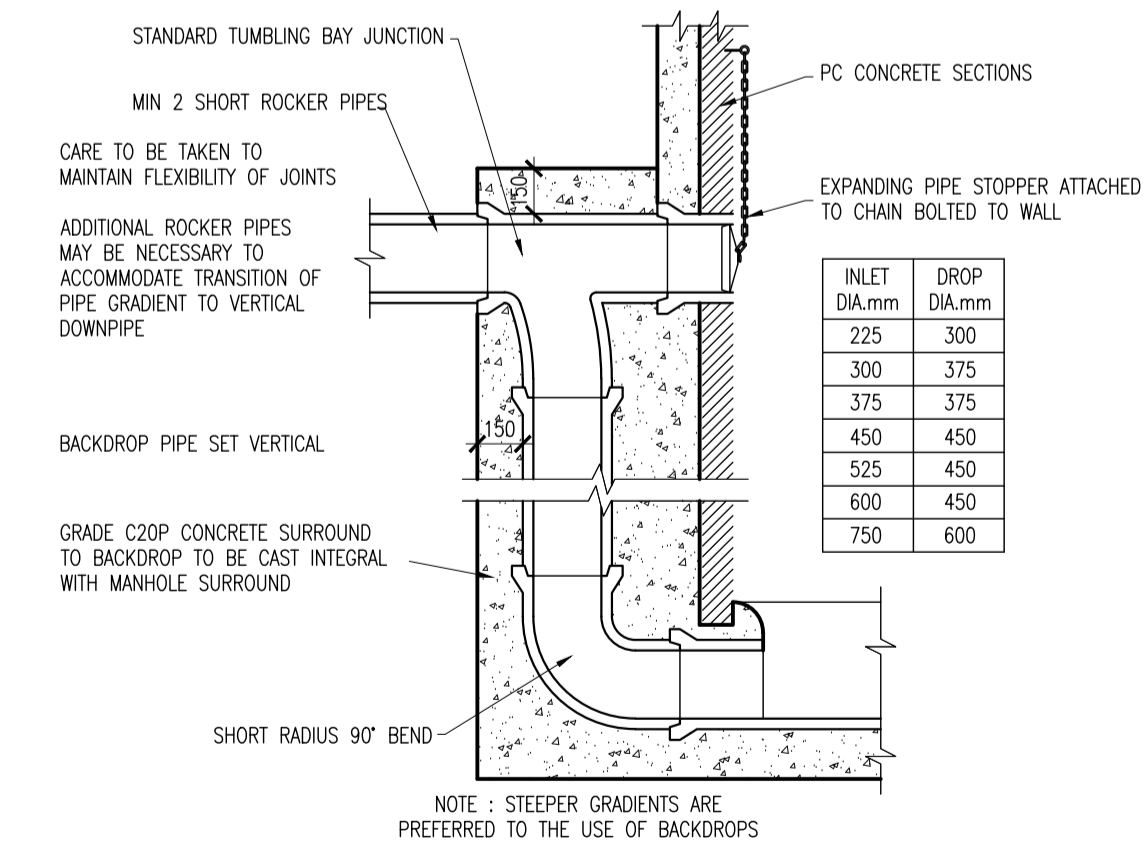

TYPICAL VERTICAL BACKDROP DETAIL
SCALE 1:25

REV	DATE	DESCRIPTION	CHK	CHKD
A	280920	STAGE 3 SUBMISSION	DMW	DMW

PLANNING SHD STAGE 3

DESIGNED	DMW	PREPARED	JJB
DATE	SEPTEMBER 2019	CHECKED	DCG

DBFL Consulting Engineers
 Dublin Office: Ormrod House, Upper Ormrod Quay, Dublin 7, Ireland. Phone: +353 1 400 4000 Fax: +353 1 400 4050
 Waterford Office: Unit 2, The Chandlers, 1-2 O'Connell Street, Waterford, Ireland. Phone: +353 51 308 500 Fax: +353 51 844 813

PROJECT
NEWTOWNPARK AVENUE SHD

DRG. TITLE
TYPICAL DRAINAGE DETAILS SHEET 1

ARCHITECT
HENRYJLYONS

SCALE	1:500 @A1	FILE REF.	190146-3011
DRG. NO.	190146-3011		A